

UTV-02

UHF PANEL ANTENNA

FEATURES

- vertical polarization
- broadband 470 ÷ 860 MHz
- 10.5 dB gain
- directional pattern
- suitable as a component in various arrays



ELECTRICAL DATA

ANTENNA TYPE	UTV-02
FREQUENCY RANGE	470 ÷ 860 MHz
IMPEDANCE	50 ohm
CONNECTOR	7/16 F or 7/8" EIA
MAX POWER	1.5 kW (7/16 F), 2.5 kW (7/8" EIA)
VSWR	≤ 1.1
POLARIZATION	Vertical
GAIN (referred to half wave dipole)	10.5 dB
HALF POWER BEAMWIDTH	E-Plane ± 15° H-Plane ± 32°
LIGHTNING PROTECTION	All Metal Parts DC Grounded

MECHANICAL DATA

DIMENSIONS	759 x 460 x 228 mm (7/16 F) 759 x 460 x 240.5 mm (7/8" EIA)
WEIGHT	15.5 kg
WIND SURFACE	0.35 m ²
WIND LOAD (at 150km/h)	0.48 kN
MAX WIND VELOCITY	220 km/h
MATERIALS	Brass, aluminium, stainless steel, teflon, fiberglass (radome)
ICING PROTECTION	Full radome
RADOME COLOUR	Orange - Green - White (standard)
MOUNTING	Directly on supporting mast or with special pipe clamps

RADIATION PATTERNS (Mid Band)

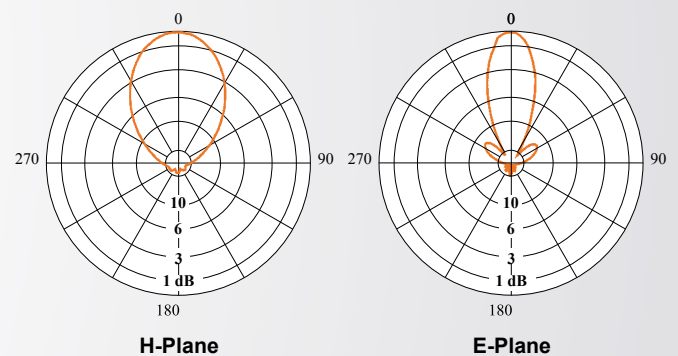

VSWR

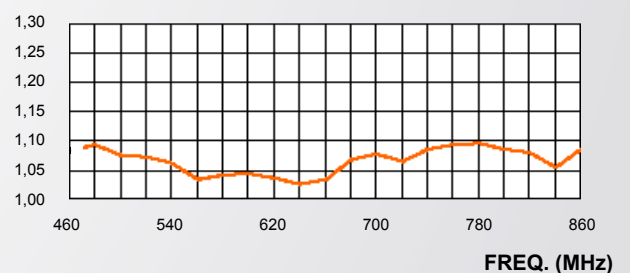

GAIN (dB)

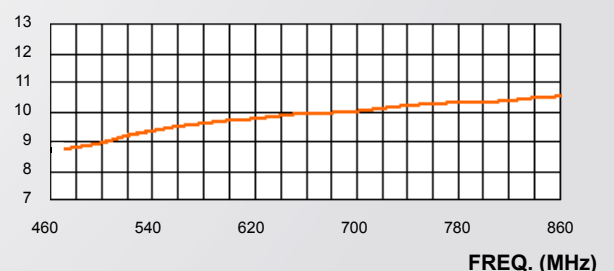

UTV-02

UHF PANEL ANTENNA

FEATURES

- radiating systems with UTV-02 panels
- omnidirectional or directional patterns
- equal or unequal power split ratio distribution network
- very high power systems
- broadband 470 ÷ 860 MHz



UTV-02/14 (6+2+6)
SEGGI, ITALY

ELECTRICAL DATA

FREQUENCY RANGE	470 ÷ 860 MHz
IMPEDANCE	50 ohm
CONNECTOR	EIA flange according to system power rating
POWER RATING	The antenna system can accept any power according to requirements
VSWR	≤ 1.05 in the operating channels
POLARIZATION	Vertical
GAIN	Refer to table
HORIZONTAL PATTERN	Any type according to requirement
VERTICAL PATTERN	Null fill, beam tilt and special requirements to order
OTHER FEATURES	The antenna system can be supplied in split feed configuration with two equal halves. Each half can accept full power.

MECHANICAL DATA

HEIGHT OF ARRAY	Subject to number of bays
TOTAL NET WEIGHT	Refer to table
WIND LOAD	Refer to table
PRESSURIZABLE	Yes
MOUNTING HARDWARE	Available upon request

UTV-02

UHF PANEL ANTENNA

HORIZONTAL PATTERNS WITH OFFSET 2,3 AND 4 FACES AT 650 MHz

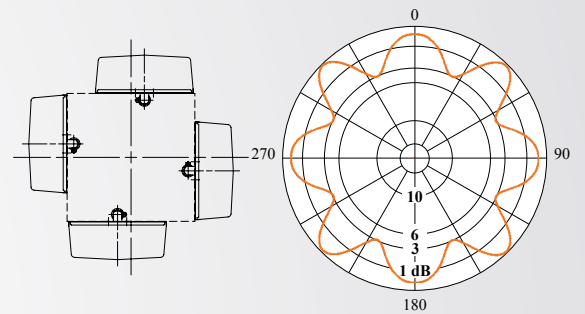
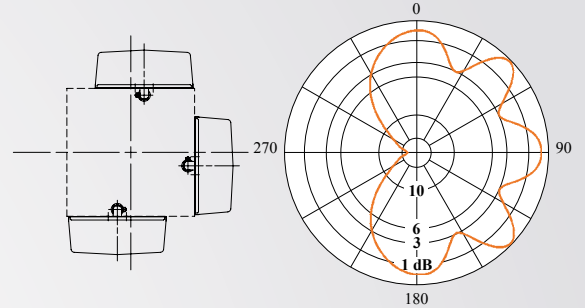
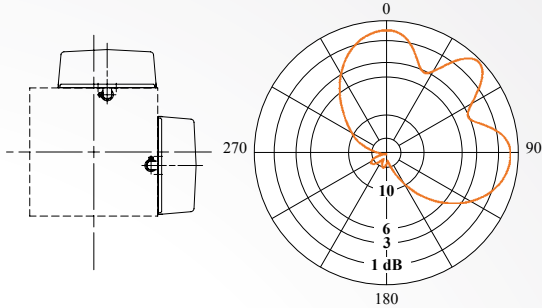

TECHNICAL DATA

NUMBER OF BAYS	PANELS PER BAY	GAIN dB (1)	GAIN TIMES (1)	WEIGHT kg (2)	ANTENNA HEIGHT L m	WIND LOAD (3) KN	WIND LOAD (4) KN
2	1	13	19.9	42	1.55	1.24	4.48
	2	10	10	92		2.77	6.01
	3	8.2	6.6	134		3.30	6.54
	4	7	5	184		3.14	6.38
4	1	16	38.8	92	3.15	2.53	5.77
	2	13	19.9	184		5.62	8.86
	3	11.2	13.2	305		6.70	9.94
	4	10	10	432		6.38	9.62
6	1	17.8	60	134	4.75	3.83	7.07
	2	14.8	30.2	305		8.48	11.72
	3	13	19.9	414		10.09	13.33
	4	11.8	15.1	480		9.61	12.85
8	1	19	79.4	184	6.35	5.14	8.38
	2	16	39.8	432		11.32	14.56
	3	14.2	26.4	480		13.48	16.72
	4	13	19.9	647		12.84	16.08
10	1	20	100	244	7.95	6.41	9.65
	2	17	50	458		14.19	17.43
	3	15.8	38	730		16.88	20.12
	4	14	25.1	975		16.08	19.32
12	1	20.8	120.2	305	9.55	7.21	10.45
	2	17.8	60.2	480		17.06	20.30
	3	16	39.8	915		20.28	23.52
	4	14.8	30.2	1090		19.31	22.55
16	1	22	158.5	432	12.75	10.29	13.53
	2	19	136.6	647		22.76	26
	3	17.2	52.5	1090		27.07	30.31
	4	16	68.3	1390		25.78	29.02

- UP -

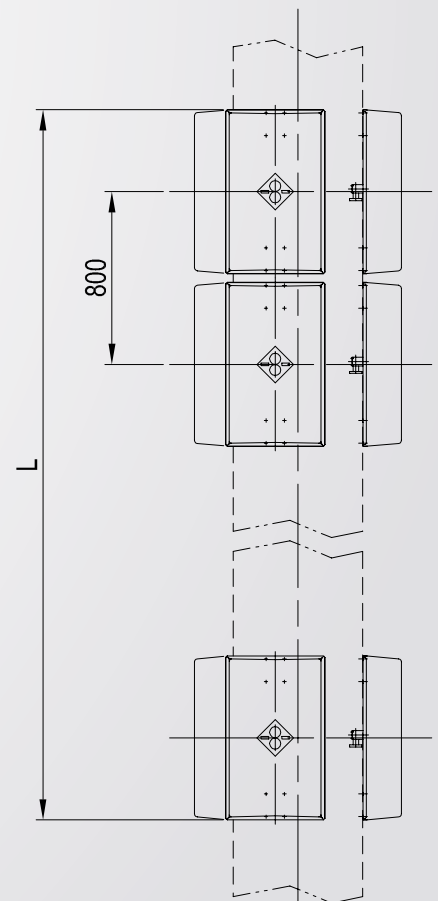

(1) referred to half wave dipole. Losses of power distribution network not included.
 (2) without mounting hardware.
 (3) Without top mast, v= 150 km/h (4) With top mast, v= 150 km/h

UTV-02

UHF PANEL ANTENNA

DIMENSIONAL DETAILS

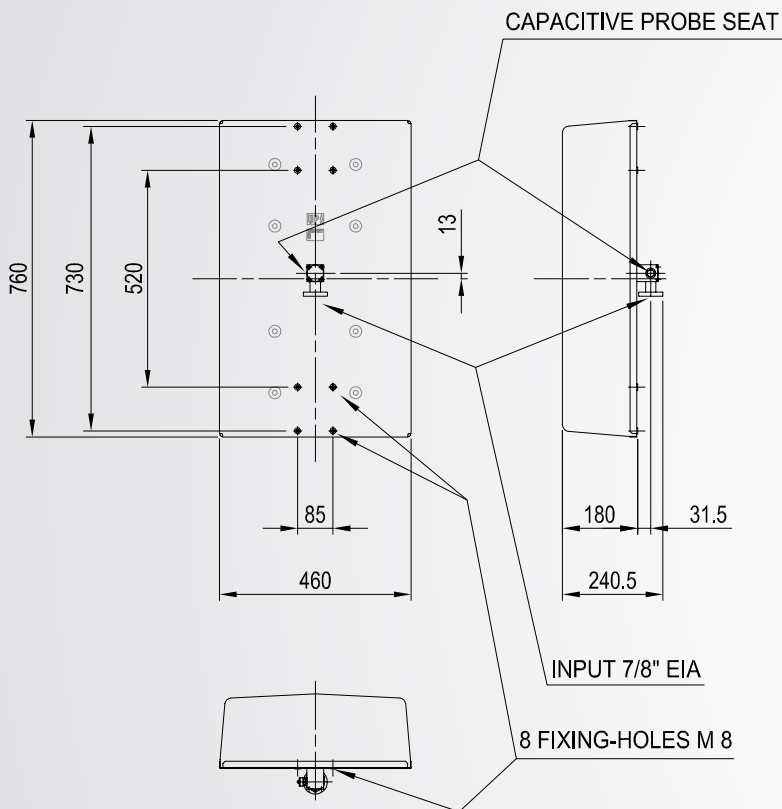

VERTICAL PATTERN

