

Rosenheim, 01.06.2019

## **Information über gesellschaftsrechtliche Änderung Information about change in corporate legal status**

Zum 1. Juni 2019 wurde das Geschäftsfeld "Broadcast" der KATHREIN SE (vormals KATHREIN-Werke KG) auf die KATHREIN Broadcast GmbH übertragen.

Die neuen Firmendaten lauten ab 01.06.2019 wie folgt:

**KATHREIN Broadcast GmbH  
Ing.-Anton-Kathrein-Str. 1 - 7  
83101 Rohrdorf, Deutschland**

**Steuer Nr.: 156/117/31113  
UST-Ident-Nr.: DE 323 189 785  
Handelsregister Traunstein: HRB 27745**

E-Mail: [broadcast@kathrein.de](mailto:broadcast@kathrein.de)  
[www.kathrein-bca.com](http://www.kathrein-bca.com)

---

As of 1st June 2019, KATHREIN SE's (formerly KATHREIN-Werke KG) business unit "BROADCAST" has been transferred to KATHREIN Broadcast GmbH.

From 1st June 2019, the new company data are:

**KATHREIN Broadcast GmbH  
Ing.-Anton-Kathrein-Str. 1 - 7  
83101 Rohrdorf, Germany**

**Tax Payer's ID No.: 156/117/31113  
VAT Reg. No.: DE 323 189 785  
Commercial Register Traunstein: HRB 27745**

E-Mail: [broadcast@kathrein.de](mailto:broadcast@kathrein.de)  
[www.kathrein-bca.com](http://www.kathrein-bca.com)

- Omnidirectional antenna with preferred direction of radiation.
- Mounting to tubular masts.

Order No.	774846
Input	7-16 female
Max. power	2 kW
Frequency range	195 – 230 MHz
VSWR	< 1.25
Gain (at mid-band)	2 dBd
Impedance	50 Ω
Polarization	Vertical
Weight	6 kg
Wind load (at 160 km/h)	Lateral: 90 N
Max. wind velocity	225 km/h

Material: Hot-dip galvanized steel.

Mounting: To pipes of 60 – 125 mm diameter by means of mounting clamp, supplied.

Grounding: Via mounting parts.

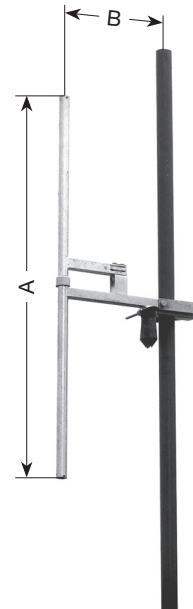

A: ~ 645 mm  
B: ~ 440 mm

### Radiation Patterns (at mid-band)

(Radiator mounted onto a slim steel tube, tower effects not considered)

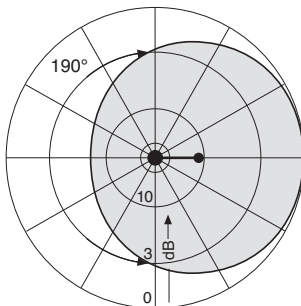

Horizontal Radiation Pattern

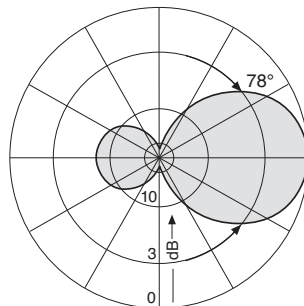

Vertical Radiation Pattern

936.5134 Subject to alteration.

**Please note:**

**As a result of more stringent legal regulations and judgements regarding product liability, we are obliged to point out certain risks that may arise when products are used under extraordinary operating conditions.**

The mechanical design is based on the environmental conditions as stipulated in ETS 300 019-1-4 and thereby respects the static mechanical load imposed on an antenna by wind at maximum velocity.

Extraordinary operating conditions, such as heavy icing or exceptional dynamic stress (e.g. strain caused by oscillating support structures), may result in the breakage of an antenna or even cause it to fall to the ground.

Cylindrical bodies can show crosswind response, which can cause the supporting structure to oscillate and to be damaged. Prismatic bodies, even with non-circular cross-section can show crosswind response, which can cause the supporting structure to oscillate (see EN 1991-1-4 or EN 1993-3-1).

These facts must be considered during the site planning process.

The maximum wind velocities listed should be understood in the sense of working values according to DIN and EN standards. These values include a safety factor (1.5) below the ultimate limit state (elastic limit or permanent deformation). For these wind velocities we guarantee the mechanical safety and the electrical integrity of our antennas.

**The installation team must be properly qualified and also be familiar with the relevant national safety regulations.**

**The details given in our data sheets have to be followed carefully when installing the antennas and accessories.**

**The limits for the coupling torque of RF-connectors, recommended by the connector manufacturers must be obeyed.**

**Any previous datasheet issues have now become invalid.**

Our quality assurance system and our environmental management system apply to the entire company and are certified by TÜV according to EN ISO 9001 and EN ISO 14001.

