

Panel Antenna

470-654 MHz

H	V	X
---	---	---

- Directional antenna for elliptical polarizations.

Part Number	750000049
Input	7/8" EIA flange elbow
Max. power	2 kW per input
Frequency range	470-654 MHz
VSWR	< 1.15
Gain (at mid-band)	9 dBd (horizontal) 5.2 dBd (vertical)
Impedance	50 Ohm
Polarization	elliptical (70% horizontal/30% vertical)
Dimensions	W: 623 mm x H: 992 mm x D: 195 mm
Weight	16 kg
Wind load (at 160 km/h)	Frontal: 900 N Rearside: 1000 N Lateral: 340 N
Max. wind velocity	225 km/h

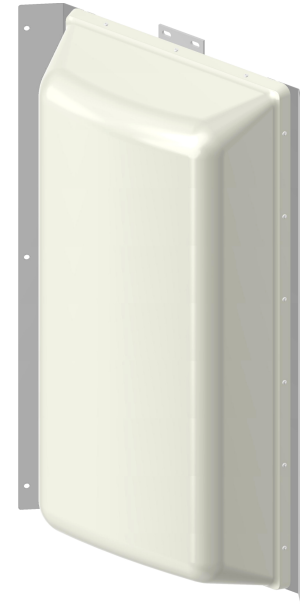

- Material** Reflector screen and dipoles: Weather-resistant aluminum, tin-plated brass.
Protective cover: Fiberglass.
Attachment plate: Hot-dipped galvanized steel.
- Radome color** RAL 9016 (traffic white), other radome colors on request.
- Mounting** Using the M 8 x 35 mm screws (supplied) to suitable steel spine, interface or mounting brackets.
- Grounding** Via mounting parts.
- Ice protection** The dipoles remain fully functional even in icy conditions as the fiberglass cover protects the whole antenna.
- Note** Nominal Dimensions: For detailed information, please refer to the technical drawing.

Mid-band radiation patterns for horizontal polarization

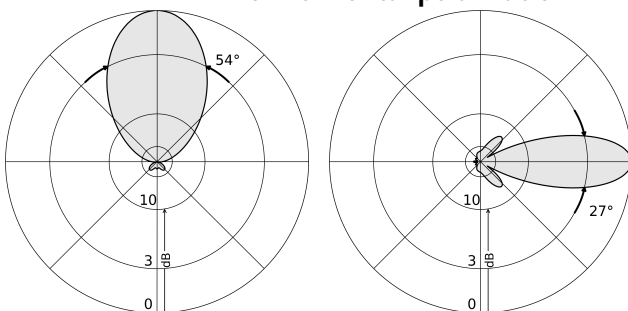

Horizontal Radiation Pattern

Vertical Radiation Pattern

Mid-band radiation patterns for vertical polarization

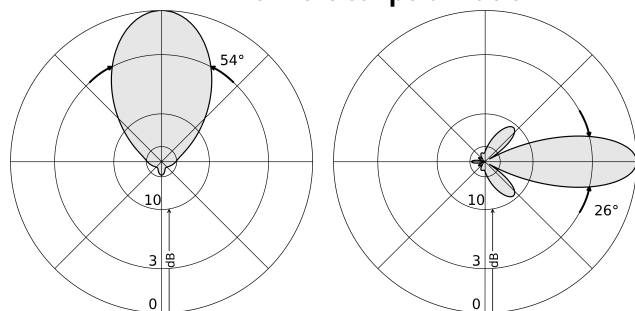

Horizontal Radiation Pattern

Vertical Radiation Pattern

Please note

As a result of more stringent legal regulations and judgements regarding product liability, we are obliged to point out certain risks that may arise when products are used under extraordinary operating conditions.

The mechanical design is based on the environmental conditions as stipulated in ETS 300 019-1-4 and thereby respects the static mechanical load imposed on an antenna by wind at maximum velocity.

Extraordinary operating conditions, such as heavy icing or exceptional dynamic stress (e.g. strain caused by oscillating support structures), may result in the breakage of an antenna or even cause it to fall to the ground.

Cylindrical bodies can show crosswind response, which can cause the supporting structure to oscillate and to be damaged. Prismatic bodies, even with non-circular cross-section can show crosswind response, which can cause the supporting structure to oscillate (see EN 1991-1-4 or EN 1993-3-1).

These facts must be considered during the site planning process.

The maximum wind velocities listed should be understood in the sense of working values according to DIN and EN standards. These values include a safety factor (1.5) below the ultimate limit state (elastic limit or permanent deformation). For these wind velocities we guarantee the mechanical safety and the electrical integrity of our antennas.

The installation team must be properly qualified and also be familiar with the relevant national safety regulations.

The details given in our data sheets have to be followed carefully when installing the antennas and accessories.

The limits for the coupling torque of RF-connectors, recommended by the connector manufacturers must be obeyed.

Any previous data sheet issues have now become invalid.

Our quality assurance system applies to the entire company and is certified to EN ISO 9001.